



Install your **future**



SYSTEM **KAN-therm**

ultraLINE

Ø **14-32 mm**



KAN company

KAN is an experienced and well-known Polish producer of modern and complex installation systems KAN-therm recognised on the international arena.



Since opening its business activity in 1990, KAN-therm has built its position on strong pillars: professionalism, innovativeness, quality and development. Nowadays, it employs more than 1100 people. It has a branch network in Poland and international offices around the world. The products with the label KAN-therm are exported to 68 countries on different continents. The distribution chain covers Europe and a significant part of Asia, Africa and America.

> 30

years of experience in the installation market

68

countries to which we export

> 1100

employees worldwide



SYSTEM KAN-therm

ultraLINE

Ø14-32 mm

This is an innovative and unique technical solution on the installation market, designed for both, standard internal heating and drinking water systems, as well as specialised piping such as compressed air.

3 pipe types
2 fitting materials
1 sliding sleeve

The unique, o-ringless fitting design and flexible configuration of the complete end solution provide great convenience for installers and designers. The flexibility of the KAN-therm ultraLINE system configuration lies in the ability to use different pipe types with the same brass or PPSU fittings and plastic (PVDF) sleeves.

KAN-therm ultraLINE is an excellent alternative to internal distributions, heating or cooling installations and hot and cold water installations in multi-family housing. The range of diameters available, up to 32 mm, allows complete heating, cooling and tap water systems in single-family houses.



- 01** Flexible choice of material
- 02** Symmetrical sliding sleeve
- 03** Optimised hydraulics
- 04** 270° assembly
- 05** O-ringless design



Benefits

01 Flexible choice of material	3 pipe types PERTAL ² , PERT ² and PEXC. 2 fitting types: brass and PPSU. 1 plastic (PVDF) sleeve.
02 Symmetrical sliding sleeve	Can be mounted on both sides.
03 Optimised hydraulics	Reduced diameter constriction and less pressure loss.
04 270° assembly	Guarantee of easy installation, even in the most hard-to-reach places; unique design allows to approach with tools at an angle of up to 270°
05 O-ringless design	The absence of additional sealing and the special shaping of the fitting stub guarantees 100% tightness and mechanical strength of the connections.
06 Safety guarantee	Exceptional strength proven under the toughest conditions.
07 Stopper	Elimination of contact between the aluminium layer and the brass body and reducing the risk of corrosion.
08 Mechanical "bumpers"	In the construction of ultraLINE sliding sleeve forks protect fittings and sleeves from damage during assembling. Easy detection of loose connections.



Top quality material

All KAN-therm ultraLINE system elements are manufactured from the top quality materials. As a result, installations made up of these products are distinguished by their high hygienic performance in relation to drinking water. This is proven by certificates from renowned certification bodies.

Switch from Push to ultraLINE

With the special ultraLINE/Push connecting set, it is possible to change from KAN-therm Push to KAN-therm ultraLINE technology quickly and easily. The completed connection can be concealed within the building partitions. Extend, renovate or replace your installations with the latest ultraLINE technology and maintain the highest aesthetic standards.

Long-term, trouble-free operation

O-ringless fitting design and sliding sleeve technology guarantee high system resistance to assembly errors and material ageing during operation of the installation. The system is therefore characterised by high installation and operational safety and a long service life.



Brass and PPSU fittings

All system fittings are available in two types, PPSU and brass. The threaded fittings are made exclusively in brass. All for the sake of safety and the longterm, trouble-free operation of the completed installation.

Many advantages in one design

This unique product brings together the key advantages of different pipe designs. Fittings and pipes are joined using a proven and reliable sliding sleeve technology.

30 years of experience

KAN-therm ultraLINE is 30 years of KAN experts' experience in the design, manufacture and operation of complete technical solutions for installation technology.

Applications

System KAN-therm ultraLINE system is a completely versatile solution. High pressure and temperature resistance as well as high hygienic mechanical strength allow to use the product for the construction of virtually any installation in a typical single-family, multi-family houses and public buildings.

KAN-therm ultraLINE can be used without any obstacles even in industrial installations, for instance in compressed air installations.

Pipes with aluminum layer that are available in the system offer make the solution also dedicated to all installations where the key factor is maximum limiting the thermal elongation of the pipeline and achieving high aesthetics, e.g: minimizing the effect of "hanging curtains" – pipeline sections between the fixing points.

The lack of shape memory effect in pipes with aluminium layer (can retain the shape they take) gives great freedom and comfort in installation of bigger-diameter pipelines. Using the given pipe type results in reducing the number of additional profiling and anchoring elements in the pipeline

KAN-therm ultraLINE pipes with aluminium layer	KAN-therm ultraLINE pipes with EVOH layer	
PERTAL ² 14×2	PEXC 14×2	PERT ² 14×2
PERTAL ² 16×2,2	PEXC 16×2,2	PERT ² 16×2,2
PERTAL ² 20×2,8	PEXC 20×2,8	PERT ² 20×2,8
PERTAL ² 25×2,5		
PERTAL ² 32×3		



POTABLE WATER



HEATING



TECHNOLOGICAL
HEAT



COOLING



COMPRESSED
AIR



TECHNICAL
GASES



UNDERFLOOR
HEATING AND
COOLING



WALL HEATING
AND COOLING



CEILING HEATING
AND COOLING



EXTERNAL SURFACE
HEATING AND
COOLING

Pipes

KAN-therm ultraLINE system offer includes pipes with aluminium and EVOH layers. With an offer configured this way the idea of ultraLINE product gives a possibility of flexible configuration of the end technical solution by an installation designer, an installer or investor unprecedented on the market.

The choice of a suitable solution can be determined not only by the preferences of those involved in a specific project, but also by the nature of the project, e.g. the need for surface installation in sacred or historic buildings, where pipes with an aluminium layer will have much better performance characteristics.

1 Polyethylene PE-RT

3 Aluminium layer

4 Binding layer

5 Polyethylene PE-RT

Polyethylene pipes with aluminium layer

Pipes with aluminium layer consist of:

the **inner layer** (base pipe) made of PE-RT polyethylene with improved thermal resistance, the **middle layer** in the form of a specially selected, flexible laser butt-welded aluminium strip, the **outer layer** (alloy) of polyethylene with improved thermal performance PE-RT.

The aluminium layer ensures diffusion tightness and makes the pipes have 8 times less thermal expansion than polyethylene pipes with the EVOH layer. Thanks to the butt-welding of the aluminium layer, the pipes are perfectly round cross-section. Pipes in the entire range of diameters, i.e. Ø14×2; Ø16×2.2; Ø20×2.8 Ø25×2.5; Ø32×3 are available in two types: without thermal insulation, with thermal insulation of different thickness*.

* details in KAN-therm product catalogue

Dimensional specifications for PERTAL² pipes

DN	De × t	t	Di	Size series S	Unit weight	Capacity	Packing
	[mm × mm]	[mm]	[mm]		[kg/m]	[l/m]	[m]
14	14×2,0	2,0	10,0	3,0	0,097	0,079	200
16	16×2,2	2,2	11,6	3,0	0,114	0,106	200
20	20×2,8	2,8	14,4	3,0	0,180	0,163	100
25	25×2,5	2,5	20,0	4,5	0,239	0,314	50
32	32×3,0	3,0	26,0	4,8	0,365	0,531	50





PERT² and PEXC polyethylene pipes with EVOH layer

PERT² and PEXC pipes in the KAN-therm ultraLINE offer (diameter range 14-20 mm) are made in five-layer structure.

This means that the EVOH anti-diffusion layer, which protects the system against oxygen penetration into the pipeline, is made as an inner layer covered with an additional layer of PE-XC or PE-RT polyethylene (depending on the pipe type). This positioning of the EVOH anti-diffusion layer protects it from possible damage during installation.

PERT² pipes are manufactured from polyethylene with improved thermal resistance. PERT² pipes are equipped with EVOH anti-diffusion layer and can therefore be used for both heating and potable water installations. Pipes in the entire range of diameters, i.e. Ø14×2; Ø16×2.2; Ø20×2.8 are available in two types: without thermal insulation, with thermal insulation of different thickness*.

* details in KAN-therm product catalogue

PEXC pipes are manufactured from high-density polyethylene and cross-linked by electron beam ('c' method - a physical method, without the use of chemicals). PEXC pipes are equipped with an EVOH anti-diffusion layer, so they can be used in both heating and potable water installations. Pipes in the entire range of diameters, i.e. Ø14×2; Ø16×2.2; Ø20×2.8 are available in two types: without thermal insulation, with thermal insulation of different thickness*.

* details in KAN-therm product catalogue

Dimensional specifications for PERT² pipes

DN	De × t	t	Di	Size series S	Unit weight	Capacity	Packing
	[mm × mm]	[mm]	[mm]		[kg/m]	[l/m]	[m]
14	14×2,0	2,0	10,0	3,0	0,085	0,079	200
16	16×2,2	2,2	11,6	3,0	0,100	0,106	200
20	20×2,8	2,8	14,4	3,0	0,155	0,163	100

Dimensional specifications for PEXC pipes

DN	De × t	t	Di	Size series S	Unit weight	Capacity	Packing
	[mm × mm]	[mm]	[mm]		[kg/m]	[l/m]	[m]
14	14×2,0	2,0	10,0	3,0	0,085	0,079	200
16	16×2,2	2,2	11,6	3,0	0,102	0,106	200
20	20×2,8	2,8	14,4	3,0	0,157	0,163	100

Operational Parameters

PERT² and PERTAL² pipes in accordance with PN-EN ISO 21003–2 standard, PEXC pipes in accordance with PN-EN ISO 15875-2 standard may operate at below mentioned parameters:

Type of installation and application class (acc. ISO 10508)	T _{rob} /T _{max} [°C]	DN	Operating pressure Prob [bar]			Connection type	
			PEXC	PERT ²	PERTAL ²	system	threaded
Cold tap water	20	14	10	10	10	+	+
		16	10	10	10	+	+
		20	10	10	10	+	+
		25	-	-	10	+	-
		32	-	-	10	+	-
Hot tap water (class 1)	60/80	14	10	10	10	+	+
		16	10	10	10	+	+
		20	10	10	10	+	+
		25	-	-	10	+	-
		32	-	-	10	+	-
Hot tap water (class 2)	70/80	14	10	10	10	+	+
		16	10	10	10	+	+
		20	10	10	10	+	+
		25	-	-	10	+	-
		32	-	-	10	+	-
Low-temperature heating and radiant heating (class 4)	60/70	14	10	10	10	+	+
		16	10	10	10	+	+
		20	10	10	10	+	+
		25	-	-	10	+	-
		32	-	-	10	+	-
Radiator heating (class 5)	80/90	14	10	10	10	+	+
		16	10	10	10	+	+
		20	10	10	10	+	+
		25	-	-	10	+	-
		32	-	-	10	+	-

Operating temperature T_{op} in individual classes should be treated as the design temperature, maximum temperature T_{max} as the temperature before exceeding, in which the systems should be secured.

Physical properties of PERTAL² pipes

Property	Symbol	Unit	Value
Thermal expansion coefficient	α	mm/m × K	0,025
Heat conductivity	λ	W/m × K	0,43
Minimum bend radius	R _{min}	mm	3,5 × De
Internal wall roughness	k	mm	0,007

Physical properties of PERT² and PEXC pipes

Property	Symbol	Unit	PERT ²	PEXC
Thermal expansion coefficient	α	mm/m × K	0,18	0,178
Heat conductivity	λ	W/m × K	0,41	0,35
Minimum bend radius	R _{min}	mm	5 × De	5 × De
Internal wall roughness	k	mm	0,007	0,007



Fittings

The KAN-therm ultraLINE system provides the entire range of fittings required to complete even the most complex installations.

All fittings are available in plastic (PPSU) and brass. Threaded couplings are available in brass only.

The fittings are compatible with all ultraLINE pipes.



The biggest advantage of ultraLINE fittings is their construction without O-rings. The ultraLINE fitting is a single solid body with a specially shaped design allowing the assembly of connections using a sliding sleeve.

As a result, the KAN-therm ultraLINE system eliminates the risk of assembly errors, is easy and quick to install and guarantees many years of trouble-free operation. The entire range of elements available comprises the following:

- Couplings and reducers made of plastic PPSU and brass
- Steel/ultraLINE transition connectors made of brass,
- PPSU plastic and brass elbows,
- Equal and reduction tees made of plastic PPSU and brass,
- ultraLINE brass plugs,
- Brass fittings with threads,
- Brass elbows and tees with threads,
- Tap connectors with various lengths in brass design,
- Brass elbows and tees with nickel-plated pipes.

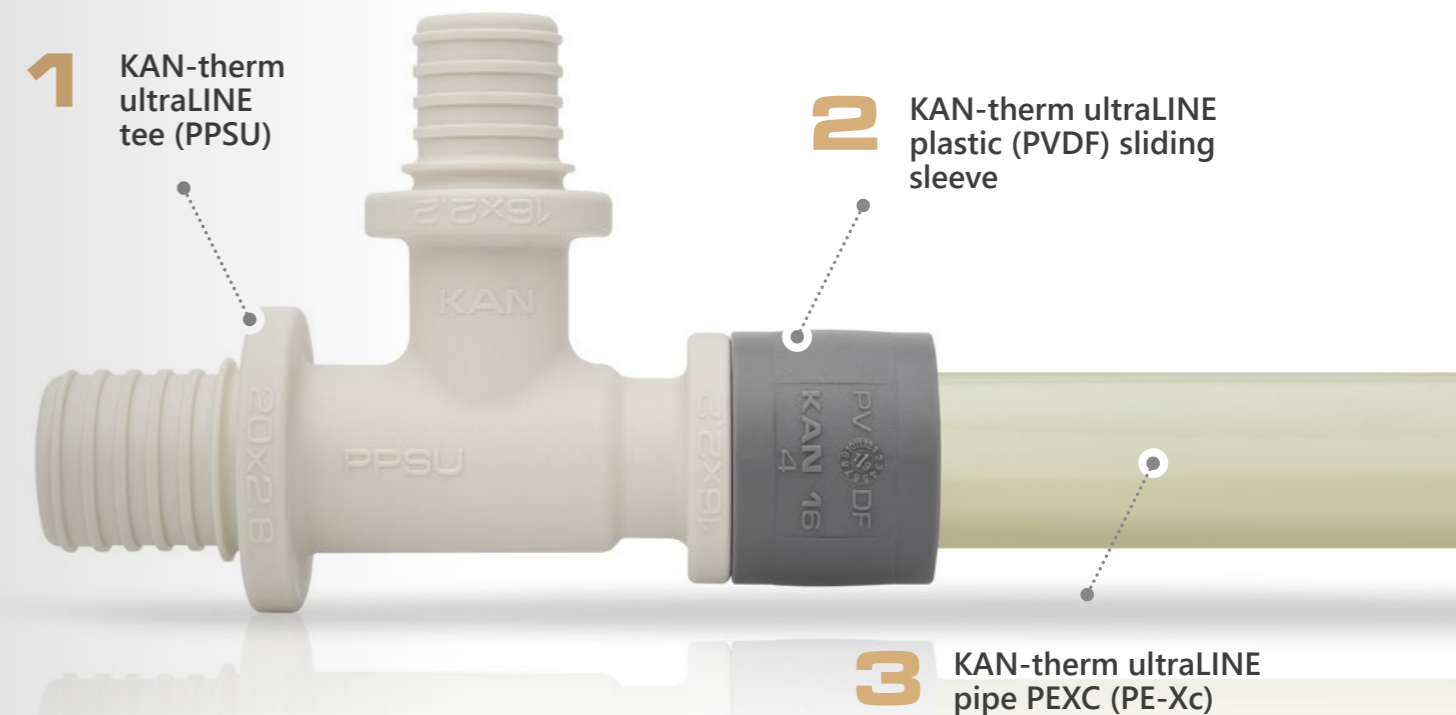

Sliding sleeves

Sliding sleeves of KAN-therm ultraLINE system are one of the most important elements responsible for connecting and sealing the pipe with the fittings. The sleeves are produced of high quality PVDF plastic.

Like the fittings, the sliding sleeves can be used with all KANtherm ultraLINE pipes.

Advantages of fitting and sliding sleeve design

- Wide range of fittings and threaded connections,
- Versatility of use, allowing the use of brass and plastic elements for virtually every type of installation,
- Wide range of plastic components (PPSU), guaranteeing the possibility of price optimization of the complete investment and securing the system against negative effects of water with unfavourable chemical composition,
- Universal design of threaded couplings ensuring safe and tight connection with various types of ultraLINE pipes,
- Design of elements in diameters 25 and 32 mm with increased internal cross-section, thanks to which the hydraulics is significantly increased and the so-called hydraulic optimization of the designed systems is enabled,
- Aesthetic look of the fittings and bright color of PPSU plastic design that significantly increases the visibility of the element in dark rooms,
- Symmetrical design of the sliding sleeves that minimizes the risk of mistakes and significantly increases convenience during assembly.



Check out how easy it is!

01 Flexible choice of material

3 pipe types: PERTAL², PERT² and PEXC
2 fitting types: brass and PPSU.
1 sleeve construction.



02 Symmetrical sliding sleeve

allows both sides assembly.



03 Optimal hydraulics

Reduced pipe internal diameter narrowing and pressure loss

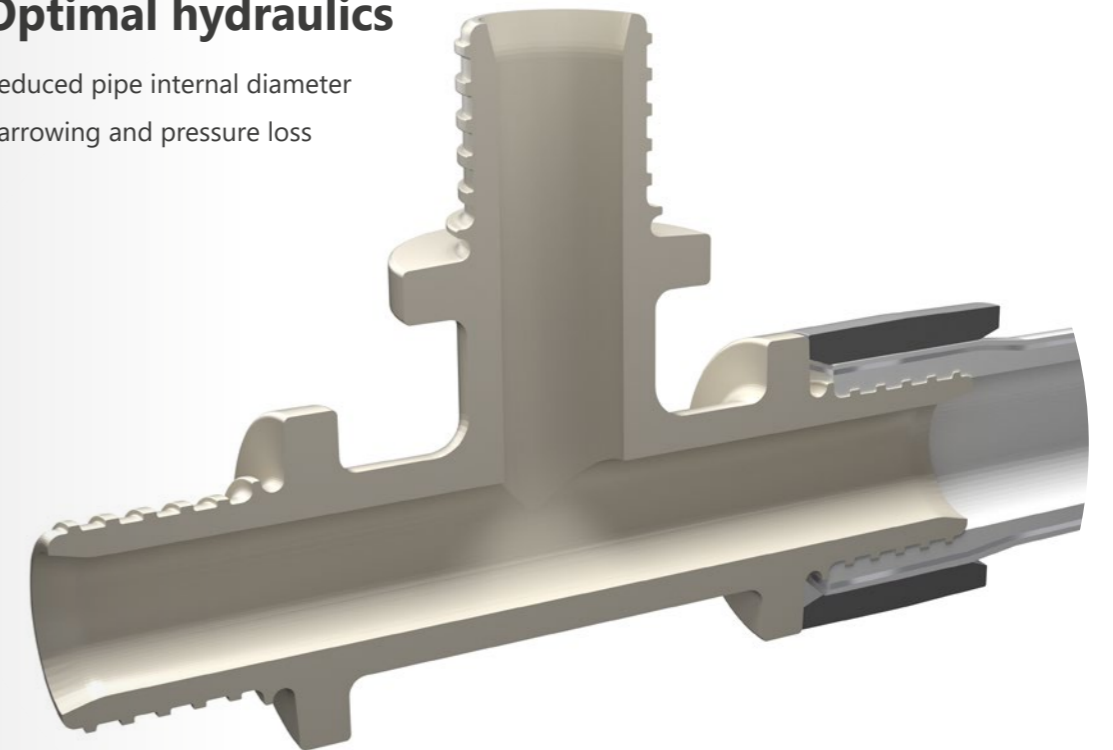

04 270° assembly

Guarantees easy installation even in the most hard-to-reach places; unique design allows to approach with tools at an angle of up to 270°



05 O-ringless connections

Absence of additional sealing and the profile of fitting nozzle guarantee 100% tightness and mechanical strength of the connection

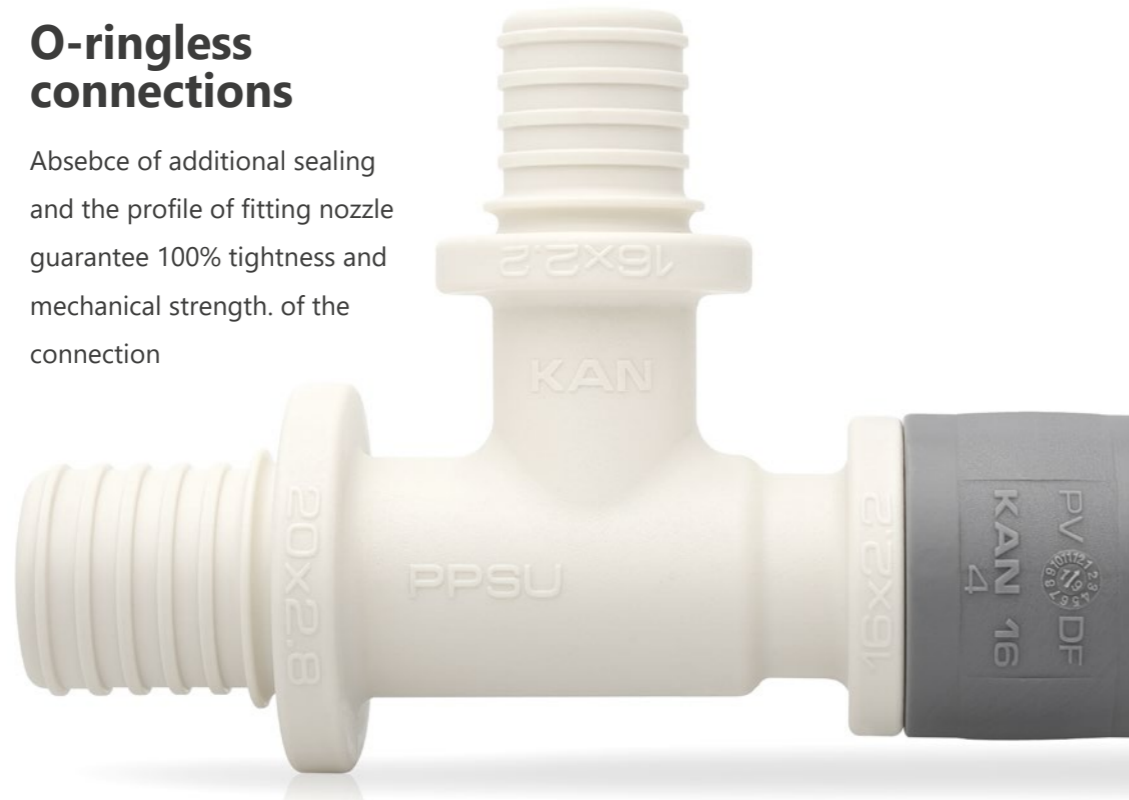

06 Safety guarantee

Exceptional strength proven under the toughest conditions.

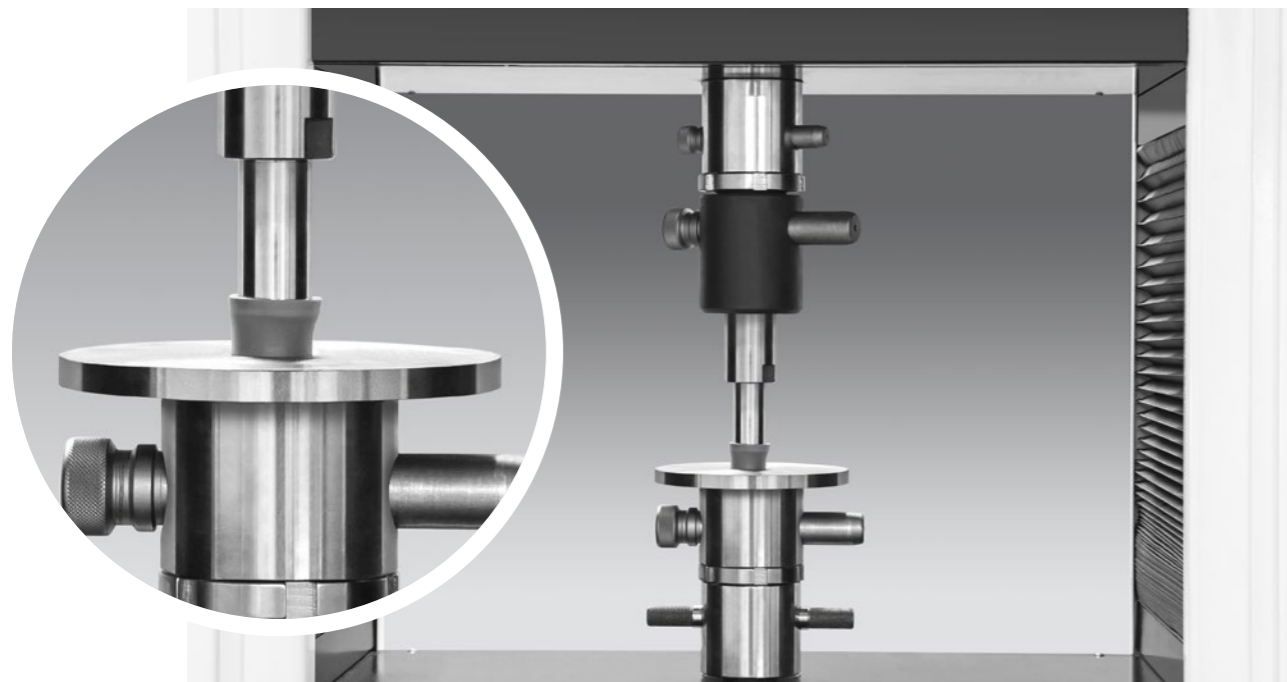

07 Stopper

Elimination of contact between the aluminium layer and the brass body, corrosion risk reduction

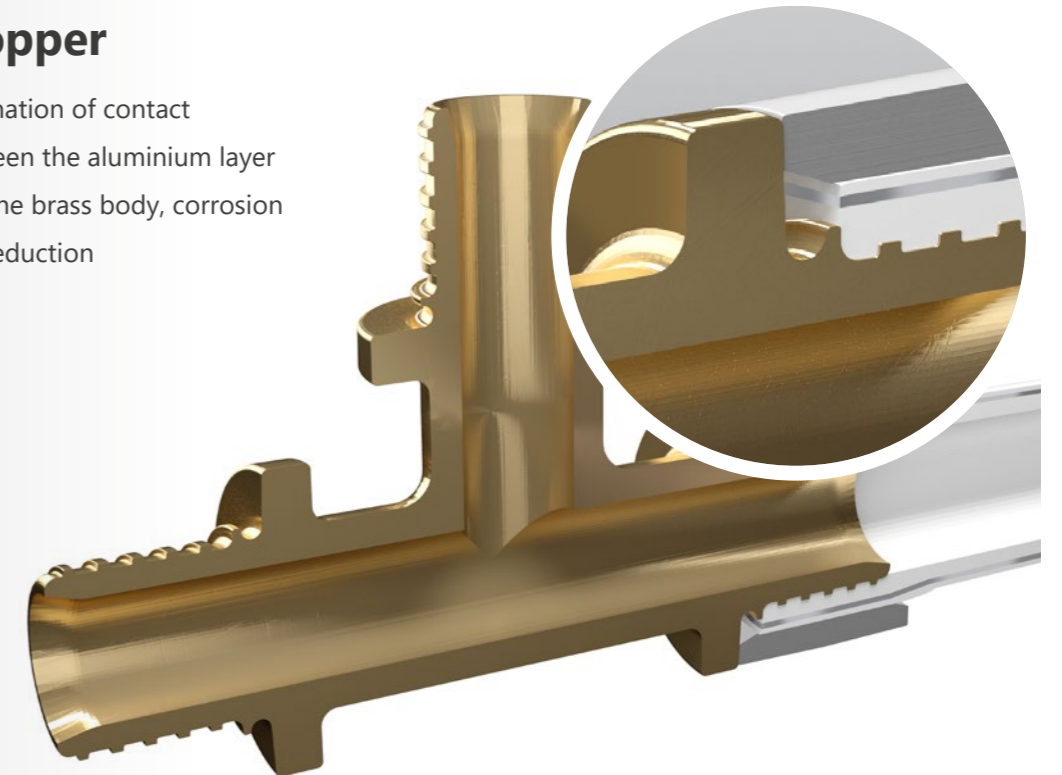

08 Mechanical "bumpers"

In the construction of ultraLINE sliding sleeve forks protect fittings and sleeves from damage during assembling. Easy detection of loose connections



Tools

KAN-therm ultraLINE system range is complemented by high quality tools that ensure strong and safe connection of the pipe and fitting. We provide our clients with professional and very convenient in everyday work battery-powered tools or practical and compact hand tools.

Range of battery powered tools

These are the latest generation of tools to speed up the assembly process. These tools are dedicated to the KAN-therm ultraLINE system and have been specially designed for optimum and safe connection assembly. They are supplied in a convenient plastic case.



A plastic case with a practical measuring ruler on the housing

Battery sliding sleeve tool



Hand tools set

The very small size of hand sliding sleeve tool allows the ultraLINE connections to be made easily even in the most hard-to-reach places. Not having to recharge the battery is a big plus when there is no access to power supply.

The same complementary accessories, i.e. forks and expanding heads, are used when working with hand and battery powered tools.



Assembly

To perform connections in KAN-therm ultraLINE system, use original KAN-therm tools only. Tools are available as individual components or in complete sets.

Making an ultraLINE connection is a few very easy and quick steps.



01 The selected KAN-therm ultraLINE pipe should be cut perpendicularly to the axis to the required length by means of pipe cutters.



02 Put the sleeve onto the pipe. Equip the hand or battery powered expander with an expanding head suitable for the pipe and its diameter.



03 Directly (!) after expansion, insert the fitting into the pipe to the last protrusion on the fitting stub.



04 Slide the sleeve with manual chain or battery powered sliding sleeve tool. The fittings may be grabbed only by their collars.



04 a Equip the sliding sleeve tool with special forks.



04 b Slide the sleeve using manual chain or battery powered sliding sleeve tool.



04 c It is possible to slide a sleeve on with the use of electric drives, typical for "Press" connections.



05 The connection is ready for the pressure testing.

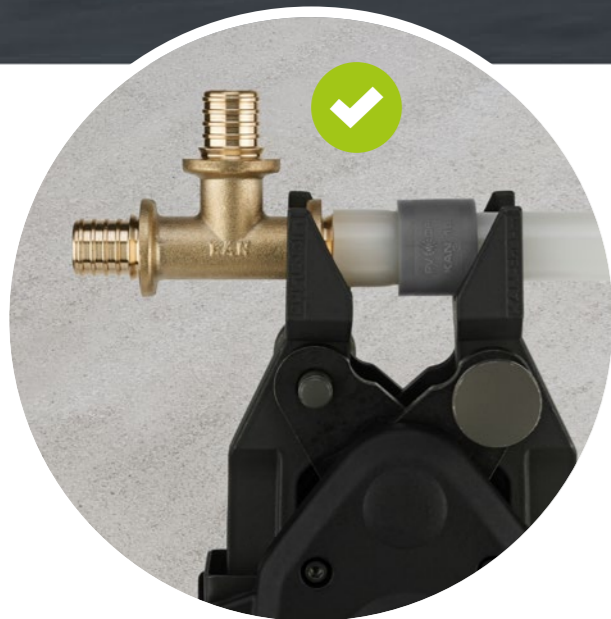

06 Pay attention to the correct position of the fittings in the forks of the tool.

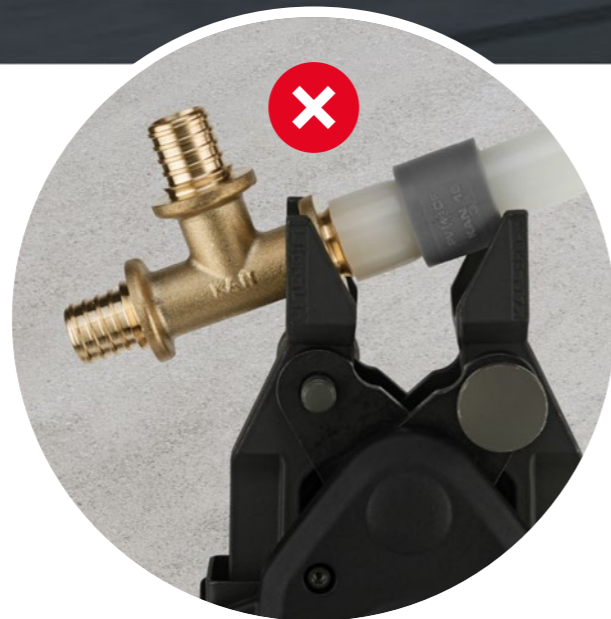

07 In case of non-compliance with this rule, the fitting and the components of the connection may be overloaded.



NOTE! Remember to expand the KAN-therm ultraLINE pipes using special expanding head suitable for the pipe type.

PERTAL² pipes with an aluminium layer are to be expanded using "silver" expanding heads (14, 16, 20, 25, 32 mm).



PERT² and **PEXC** pipes with an EVOH layer should be expanded using "black" expanding heads (14, 16, 20 mm).

Multisystem **KAN-therm**

Complete multipurpose installation system consisting of state-of-the-art, mutually complementary technical solutions for pipe water distribution installations, heating installations, as well as technological and fire extinguishing installations.

	ultraLINE	
	ultraPRESS	
	PP Green	
	Steel	
	Inox	
	Groove	
	Copper, Copper Gas	
	Sprinkler	
	PowerPress	
	Surface heating and cooling Control automation	
	Football Stadium installations	
	Cabinets and manifolds	

